

Thank you for choosing to advertise with Private Schools Guide. This specs document has been designed to assist you in providing your content. Should you require further assistance or can't find the information you require please feel free to contact us at any time.

We are here to help!

CONTACT
US

info@privateschoolsguide.com

PAGE

2

SENDING
FILES

– FIND OUT WHERE AND HOW TO SEND YOUR FILES

FINISHED
ARTWORK

TEXT
FILES

– FIND OUT HOW TO SEND VARIOUS FILE TYPES

IMAGE
FILES

PAGE

3

SIZES
AND CONTENT

– FIND OUT THE EXACT SIZE DIMENSIONS REQUIRED FOR YOUR FINISHED ARTWORK

1 / 2
PAGE

FULL
PAGE

DOUBLE
PAGE

PAGE

4

BOARDING
FEATURES

– FIND OUT THE REQUIREMENTS FOR SENDNIG BOARDING FEATURE CONTENT

SENDING
FILESSEND YOUR
ARTWORK TO

artwork@privateschoolsguide.com

OR

UPLOAD
ARTWORK @

www.privateschoolsguide.com/upload-artwork

OR

You could send large files via a third party file transfer service such as *Dropbox* or *WeTransfer*.

MAGAZINE
SIZES

All SG Magazines are
A4
plus 5mm bleed
on all sides

FINISHED
ARTWORK

Best supplied as high res CMYK .pdf @ 100% of output size (plus bleed if applicable).

- **DO NOT INCLUDE CROP MARKS** or BLEED MARKS or any other printer marks on any file
- Files sent as .jpeg, .tiff, .psd or .eps and/or RGB colour may also be acceptable.

**DO NOT
INCLUDE
CROP
MARKS**

TEXT
FILES

Please supply any plain text documents as a [standard text email](#) or [Word .doc](#) file.

- Do not embed photos in Word .doc files (see 'Image Files').

IMAGE
FILES

- .jpg, .tiff, .png, .pdf. **Email large images separately**
- Do not embed images in Word .doc files. All images should be sent as their own attachment
- All photos should be [minimum 120dpi](#) (preferably [300dpi](#))

DISPLAY
ADVERT
SIZES
AND CONTENT

IMPORTANT NOTES

**DO NOT
INCLUDE
CROP
MARKS**

For all sizes...

- BLEED - 5mm bleed only required for FULL page files where content reaches the page edge
- NO CROP MARKS - Do not include crop marks or other printer marks on any file

1/2
PAGE

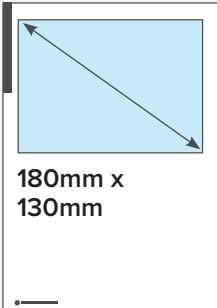

FULL
PAGE

220mm x 307mm

This size has allowed for 5mm bleed on all 4 sides.

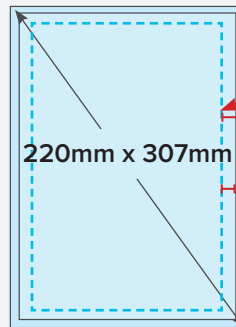

IMPORTANT CONTENT SUCH AS TEXT SHOULD BE AT LEAST 15mm FROM THE OUTER EDGE

10mm from the cut edge

Page will be cut 210mm x 297mm

DOUBLE
PAGE

OPTION A

PAGE BINDING

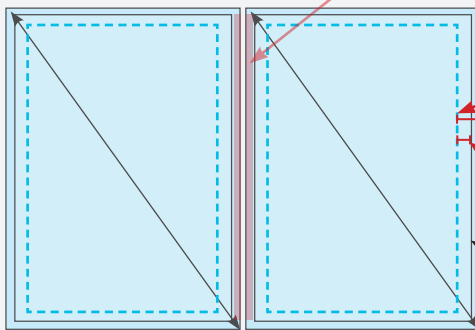

IMPORTANT CONTENT SUCH AS TEXT SHOULD BE AT LEAST 15mm FROM THE OUTER EDGE

10mm from the cut edge

Page will be cut (210mm x 297mm)

Remember to allow for the page binding when designing your artwork

OPTION B

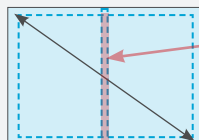

PAGE BINDING

May also be supplied @ 430mm(w) x 307mm(h)
This size has allowed for 5mm bleed on outer 4 sides.

BOARDING
FEATURES

The Boarding Section is generally comprised of a grid of 1/6 page positions, each with an identical layout.

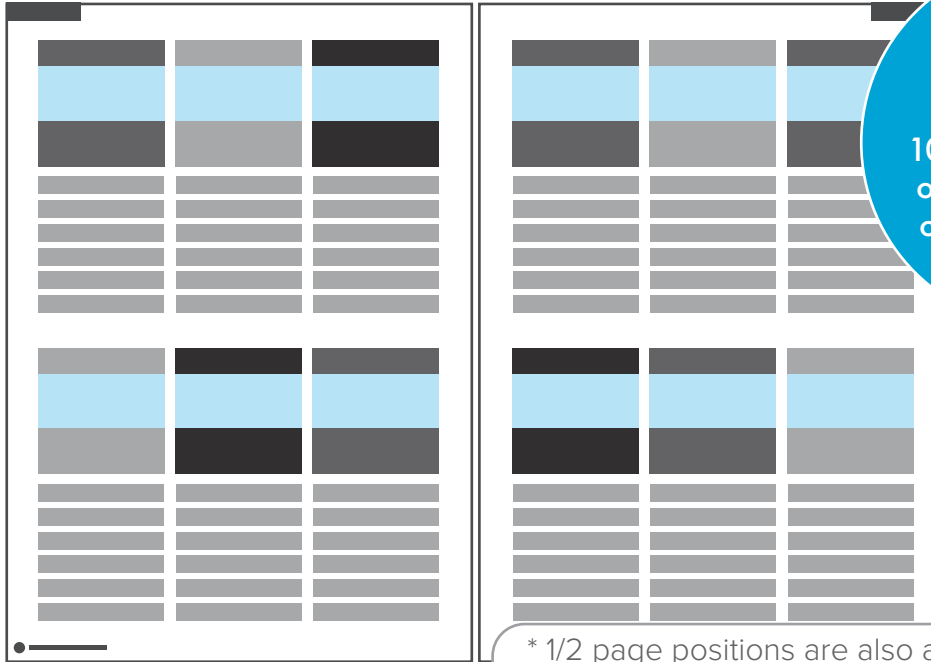

BOARDING
FEATURES

100 word boarding outline plus school crest and 1 image

* 1/2 page positions are also available in this section.
(180mm x 130mm)

BOARDING
REQUIREMENTS



← **TITLE BANNER** - presented in Individual school colours

← **IMAGE**
• PLEASE SUPPLY 1 x BOARDING IMAGE

← **INFORMATION BLOCK**
• PLEASE SUPPLY THE FOLLOWING...

- SCHOOL CREST
- BOARDING YEAR LEVELS
- AFFILIATION
- TOTAL BOARDING CAPACITY
- BOARDING FEES (optional)

← **BOARDING OVERVIEW TEXT**
• PLEASE SUPPLY 100 WORDS

BOARDING TEXT **MUST BE** WRITTEN IN **THE THIRD PERSON**

* 1/2 page boarding requires 1/2 page artwork in addition to 1/6th boarding profile.